

/SUPERBLASTER & SUPERBLASTER XL.



DISCLAIMER

⚠ WARNING

Read this manual carefully before installing and/or using this product. Failure to read the manual and to follow the printed instructions may lead to personal injury and/or damage to the product.

© 2019 MAGICFX®
All rights reserved.

Nothing from this publication may be copied, reproduced and/or published by means of printing, photocopying or by any other means, without the prior written approval of MAGIC FX.

MAGIC FX reserves the right to modify specifications stated in this manual.

TRADEMARKS

Any brand names mentioned in this manual are registered trademarks of their respective owners.

LIABILITY

MAGIC FX accepts no liability for claims from third parties arising from unauthorised use, use other than that stated in this manual, and use other than in accordance with the General Conditions registered at the Chamber of Commerce.

We further refer to the General Conditions. These are available on request, free of charge.

Although considerable care has been taken to ensure a correct and comprehensive description of all relevant components, the manual may nonetheless contain errors and inaccuracies.

Should you detect any errors or inaccuracies in the manual, we would be grateful if you would inform us. This helps us to further improve our documentation.

TABLE OF CONTENTS

Disclaimer	2
Trademarks	2
Liability	2
Foreword	4
Language	4
Revision table	4
1 Meet the MAGICFX® SUPERBLASTER (XL)!	5
1.1 Main parts	5
1.2 Technical data	6
1.3 Accessories	6
1.4 Product identification	7
1.5 Confetti	7
2 Blast safely!	8
2.1 General safety rules	8
2.2 CO ₂	8
2.3 Indoor use	9
2.4 Rigging	9
2.5 Noise level	9
2.6 Safety symbols	9
2.7 Precautions for operation	10
3 Let's blast!	11
3.1 Install the machine	11
3.2 Fill with confetti and blast	18
3.3 Replace a CO ₂ cylinder	20
3.4 Clean up	23
4 Troubleshooting	27
5 Maintenance	27
6 Correct disposal	27
7 EC Declaration of Conformity	28
7.1 SUPERBLASTER	28
7.2 SUPERBLASTER XL	29

FOREWORD

Congratulations! You have bought a great new product from MAGIC FX.

This manual contains all information required for the intended use of the equipment. Deviation from the described intended use can result in a hazardous situation and/or property damage.

This manual includes notes and warnings on safe operation of the equipment. These notes and warnings are accompanied by the following icons. Read them attentively!

⚠ DANGER

Indicates a hazardous situation that, if not avoided, will result in death or serious injury. This signal word is to be limited to the most extreme situations.

⚠ WARNING

Indicates a hazardous situation that, if not avoided, could result in death or serious injury.

⚠ CAUTION

Indicates a hazardous situation that, if not avoided, could result in minor or moderate injury.

NOTICE

Indicates information considered important, but not hazard-related (e.g. messages relating to property damage).

LANGUAGE

This document contains the original instructions in English. In case you require other languages please contact MAGIC FX.

REVISION TABLE

Document nr	Revision	Date	Description	Authored by	Checked by
PART00512	01-00	26-3-2019	Initial release	TFR	TVA

1 MEET THE MAGICFX® SUPERBLASTER (XL)!

The MAGICFX® SUPERBLASTER and the MAGICFX® SUPERBLASTER XL are special effects machines that blow confetti into the air.

Type	Capacity	Maximum shooting distance
MAGICFX® SUPERBLASTER	3-5kgs per minute	15m
MAGICFX® SUPERBLASTER XL	10-15kgs per minute	25m

Capacity and shooting distance

The MAGICFX® SUPERBLASTER (XL) is equipped with a CO₂ powered woofer. CO₂ is blown into the woofer through small holes. This creates a Venturi effect that continuously draws the confetti from the hopper, out of the woofer and into the air. The effect is accompanied by a strong hissing sound. If liquid CO₂ is applied, a white plume of smoke will be visible.

The CO₂ supply is controlled by hand with the CO₂ valve. To keep the effect going the operator must continuously fill the hopper with confetti.

1.1 MAIN PARTS

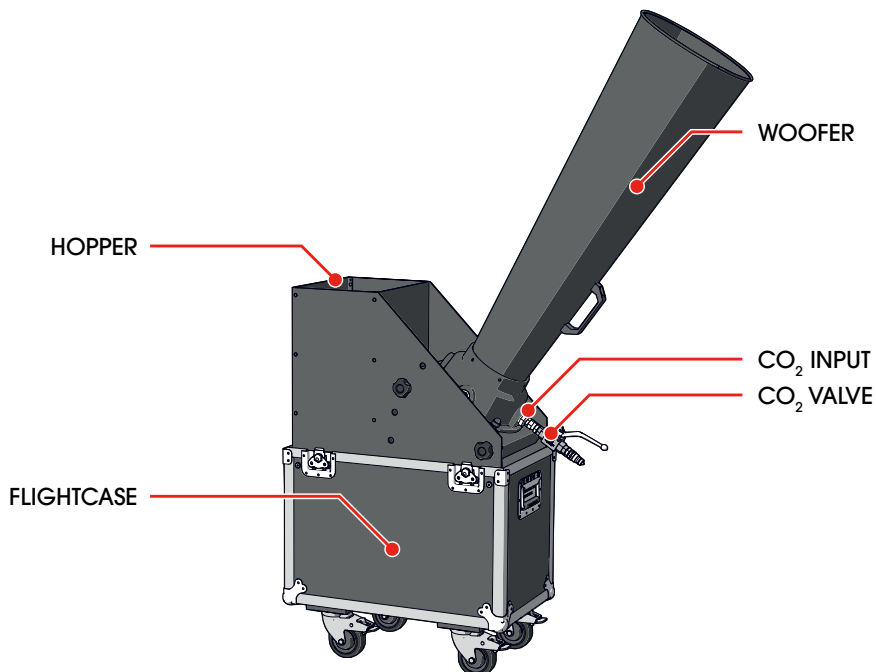

Main parts

1.2 TECHNICAL DATA

Product	Product Name	MAGICFX® SUPER BLASTER		MAGICFX® SUPER BLASTER XL	
	Product Code	MFX0801		MFX0802	
	Product Type	CONFETTI & STREAMER FX			
Main Dimensions	Length (mm/in.)	540	21.3	661	26
	Width (mm/in.)	280	11	385	15.2
	Height (mm/in.)	1040	40.9	1373	54.1
Weight	Empty weight (kg/lb.)	34	75	55	121.3
Environment	Minimum Temperature (°C/°F)	-20	-4	-20	-4
	Maximum Temperature (°C/°F)	70	158	70	158
	Humidity (Relative)	20% to 90% (non condensing)			
Controlling	Control Options	Manual			
Usage	Consumable(s)	Confetti			
	Propellant	Liquid or Gaseous CO ₂			
	Propellant Connector	0.25L/s		0.5L/s	

Technical data

1.3 ACCESSORIES

Code	Product	Included
MFX1114	CO ₂ High Pressure Hose 3/8 Male - Female, 1.25M	
MFX1105	CO ₂ High Pressure Hose 3/8 Male - Female, 2M	
MFX1106	CO ₂ High Pressure Hose 3/8 Male - Female, 3M	x
MFX1108	CO ₂ High Pressure Hose 3/8 Male - Female, 10M	
MFX1109	CO ₂ High Pressure Hose 3/8 Male - Female, 15M	
MFX1110	CO ₂ 90 Degrees Connector 3/8	
MFX1103	CO ₂ Bottle to Hose Connector	x
MFX1115	CO ₂ Bottle to Hose Connector 90 Degrees	

Accessories

Please contact MAGIC FX for additional possibilities.

1.4 PRODUCT IDENTIFICATION

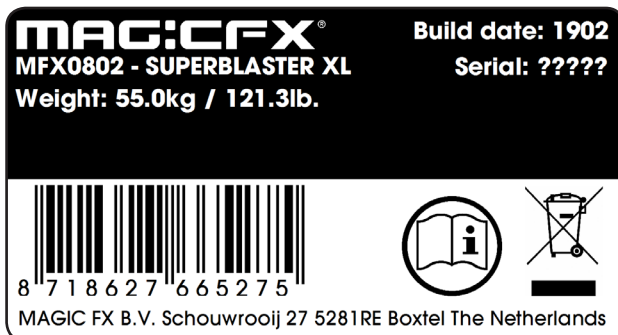
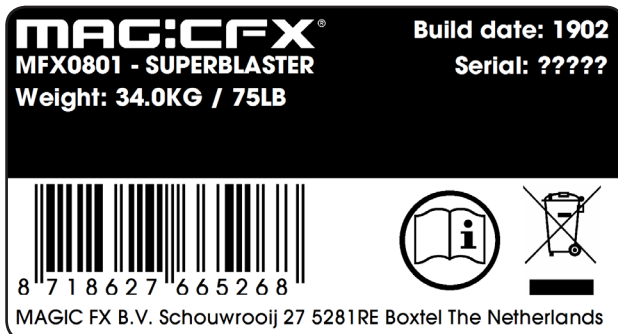

Type plate

1.5 CONFETTI

The MAGICFX[®] SUPERBLASTER (XL) can be set in 4 different angles between 42° and 90°. The output height and output distance depend on the type of confetti and the set angle. The maximum load per blast also depends on the type of confetti. Check the following table.

Type of confetti	Max. load per blast	Output distance
Metallic confetti	20 kg	25M
Paper confetti	10 kg	25M
Snow or Powder confetti	5 kg	25M

Confetti types and related loads and output

NOTICE

Wind and other weather circumstances will influence the output height and output distance of the confetti. The given values are estimated values.

2 BLAST SAFELY!

The MAGICFX® SUPERBLASTER (XL) has been designed and constructed in such a manner that it can be used safely. This applies to the use, the circumstances and the regulations as described in this documentation. Reading this documentation and following the instructions are therefore necessary for everyone who works with the MAGICFX® SUPERBLASTER (XL).

The MAGICFX® SUPERBLASTER (XL) must be used in surroundings that:

- Have a stable temperature of between -20 and 70°C.
- Have a relative humidity degree between 20% and 90% (non condensing).
- Are free of dust, corrosive gases and high concentrations of organic vapours.
- Are not situated in the vicinity of a source of vibration.

2.1 GENERAL SAFETY RULES

- Only authorised persons may work with the MAGICFX® SUPERBLASTER (XL).
- Do not use the MAGICFX® SUPERBLASTER (XL) if there are people or animals in the direct output.
- Make sure that children, unauthorised people and animals do not obtain access to the MAGICFX® SUPERBLASTER (XL).
- Do not remove any safeguards, safety caps and safety symbols.
- All required safety devices must be in good condition and function properly.
- Ensure sufficient lighting of the surroundings.
- Keep the workplace clean.

2.2 CO₂

The MAGICFX® SUPERBLASTER (XL) uses liquid or gaseous CO₂ as input. The application of CO₂ involves serious risks. Make sure that you are well informed on these risks before installation and/or operation. Always use approved CO₂ cylinders, hoses and connections. Always consult your CO₂ supplier for regulations and instructions on safe installation and use.

MAGIC FX is not liable for unsafe situations, accidents and damage that are the result of incorrect working with CO₂ gas and CO₂ cylinders.

⚠ WARNING

Inadequate installation and/or operation of a CO₂ powered machine and CO₂ cylinders can lead to death or serious injury. Always follow the instructions from this manual, from your CO₂ supplier and from local authorities.

2.3 INDOOR USE

The MAGICFX® SUPERBLASTER (XL) is designed for outdoor use and use in well-ventilated indoor spaces. When used indoors, make sure you take the necessary preparations. These preparations could include, but are not limited to:

- Consulting your CO₂ supplier.
- Calculating the reduction of oxygen for the indoor space.
- Checking the location for spots where CO₂ could accumulate and taking preventive actions.
- Installing CO₂ monitoring devices that will warn for hazardous CO₂ levels.

⚠ DANGER

Do not use the MAGICFX® SUPERBLASTER (XL) in poorly ventilated confined spaces. Exposure to high levels of CO₂ gas can cause symptoms like headache, nausea, loss of consciousness or even death.

2.4 RIGGING

Please follow the European and national guidelines for safe rigging and trussing.

2.5 NOISE LEVEL

The environmental noise level as measured at the ear is 97 dB(A). This level of noise is only reached during the short instances that the CO₂ output is active. Therefore hearing protection is not necessary.

⚠ WARNING

Do not operate the MAGICFX® SUPERBLASTER (XL) close to yourself or to others for a long period of time. If you experience any hearing loss or ringing in the ears, you should immediately stop using the unit.

2.6 SAFETY SYMBOLS

Symbol	Meaning	Position
	Read the manual carefully before use!	Front of the machine

Safety symbols

2.7 PRECAUTIONS FOR OPERATION

⚠ WARNING

Using a damaged or an improper installed machine can lead to death, serious injury or property damage. Always inspect the machine thoroughly before operation.

⚠ WARNING

Missing or obscured safety symbols on the machine can lead to death, serious injury or property damage. Make sure all safety symbols are correctly in place and visible, see Section 2.6.

⚠ CAUTION

A missing or loose-fitted woofer can lead to injury. Make sure that the woofer is correctly in place and secured.

⚠ WARNING

Make sure there are no objects near the output that can be damaged or overthrown by the MAGICFX® SUPERBLASTER (XL).

⚠ WARNING

Always create a safety zone with a distance of 3 m around the MAGICFX® SUPERBLASTER (XL).

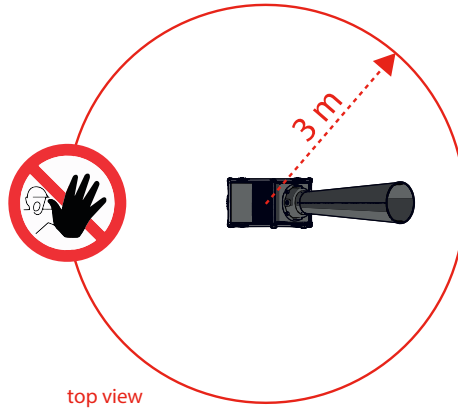

3 LET'S BLAST!

3.1 INSTALL THE MACHINE

1 Bring the cased MAGICFX® SUPERBLASTER (XL) to the desired location.

2 Unlock and remove the top cover.

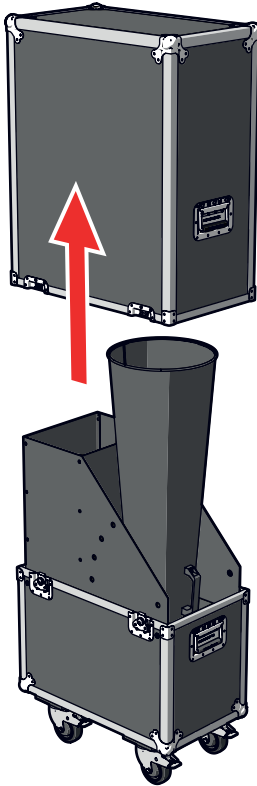

3 Take all parts out of the case:

1. Woofer
2. Woofer pin clip (2 pcs)
3. Woofer pin (2 pcs)
4. CO₂ Bottle to Hose Connector
5. CO₂ valve
6. CO₂ hose 3/8 male - female (3m)
7. Adjustable wrench

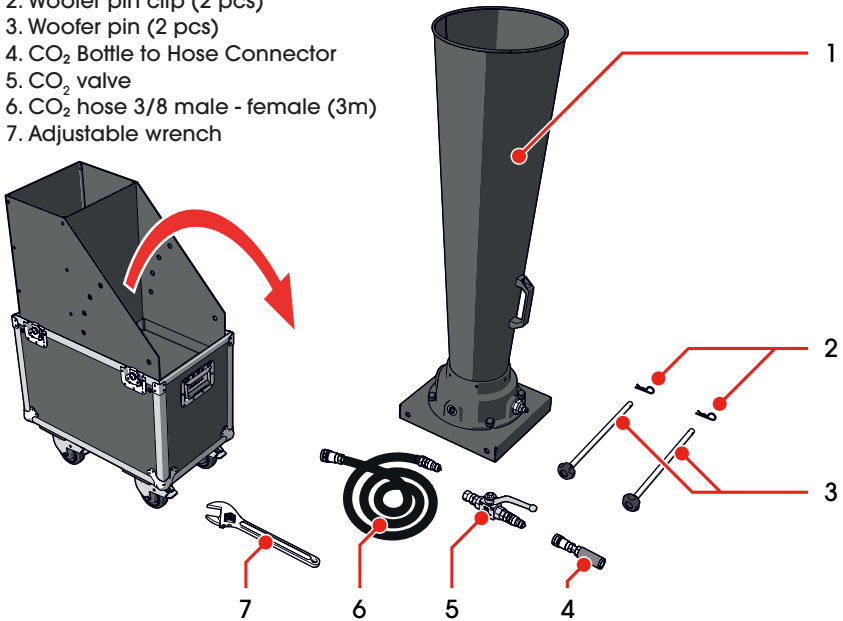

4 Place and hold the woofer in the case and insert a pin through the front pinholes. Make sure that the CO₂ input of the woofer is positioned at the front.

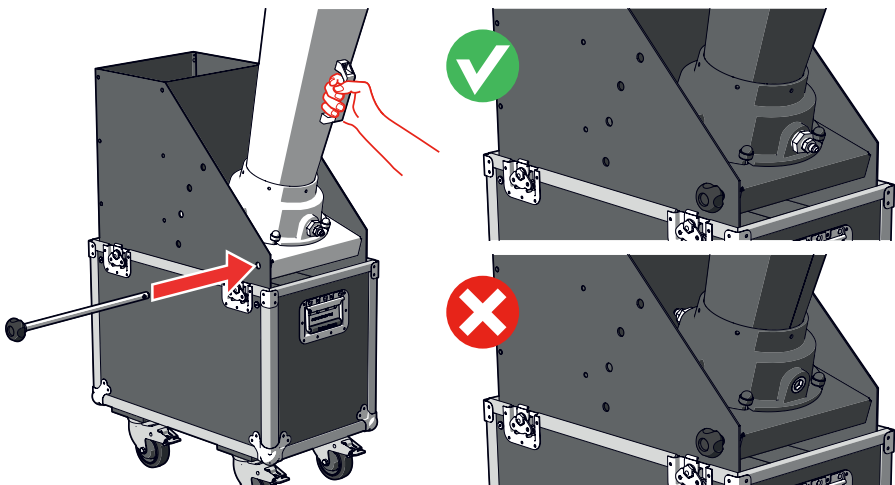

- 5 Secure the pin with a clip.

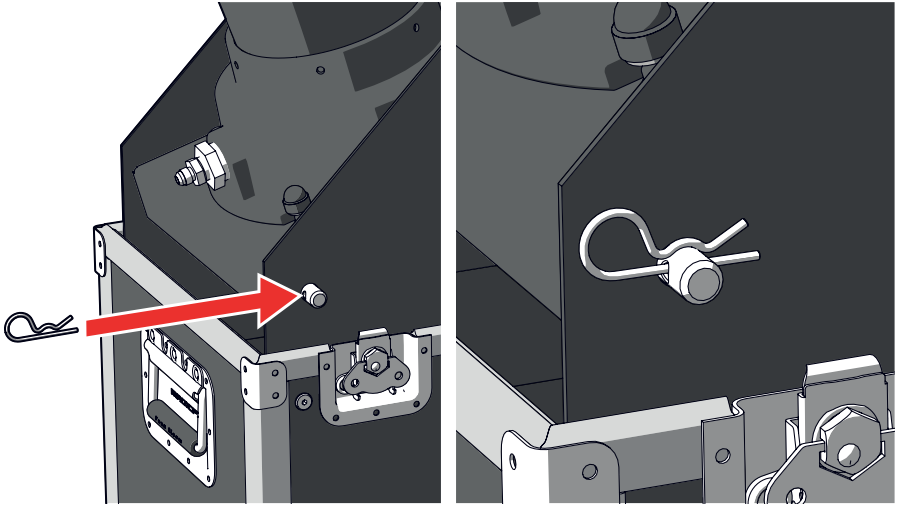

- 6 Set the angle of the woofer by aligning the back pinhole with one of the four predefined holes in the case.

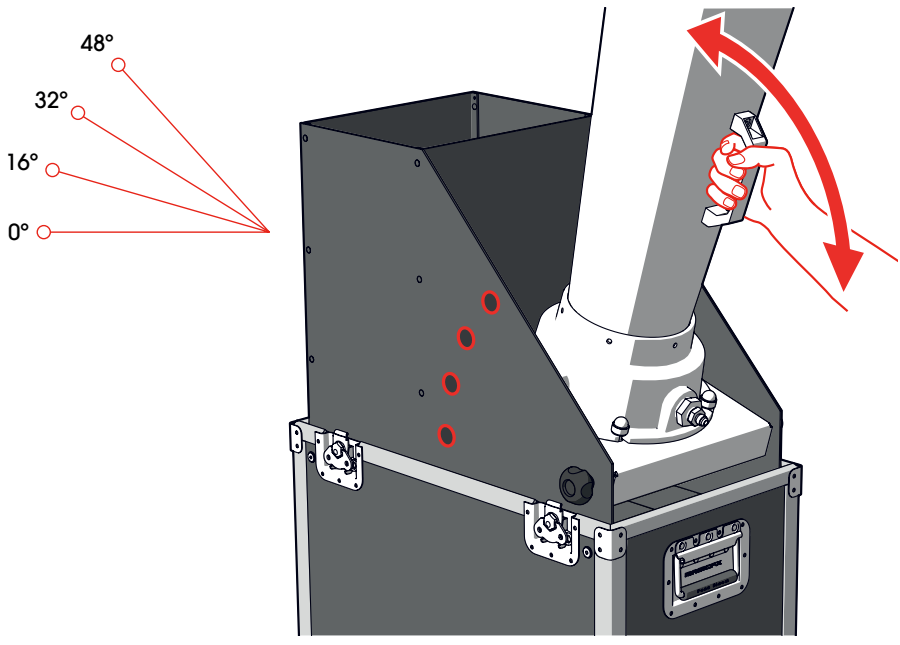

-
- 7 Insert the second pin through the back pinholes to secure the position of the woofer.

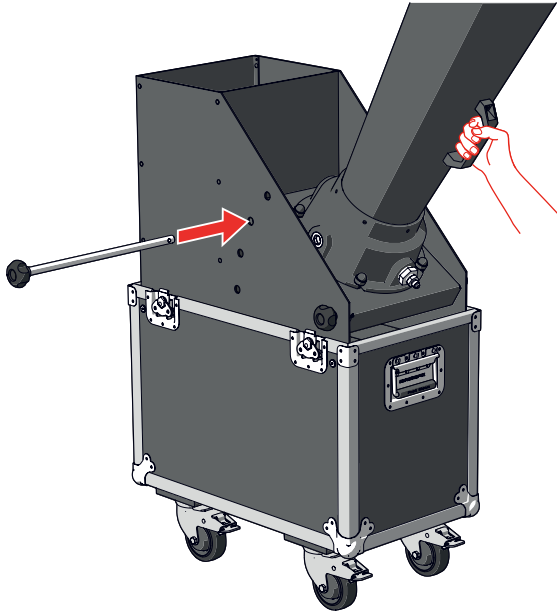

-
- 8 Secure the pin with a clip.

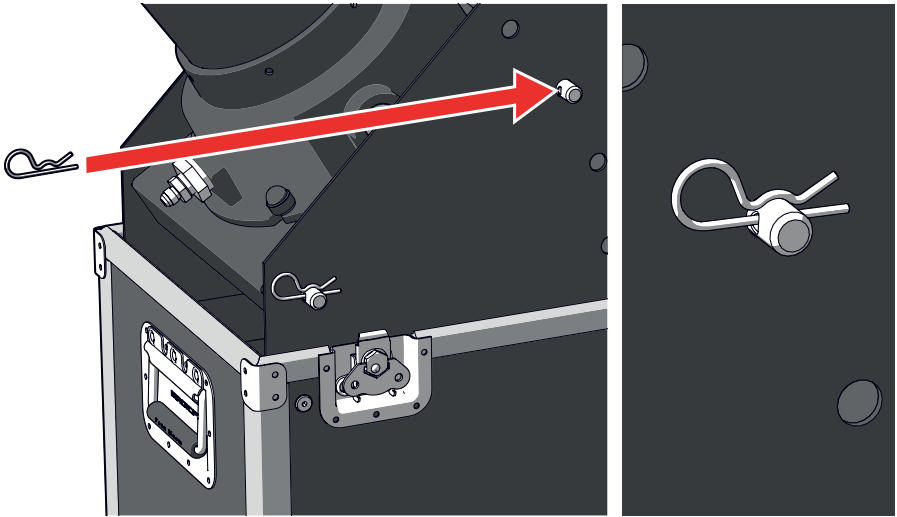

-
- 9 Position the machine and set the brakes.

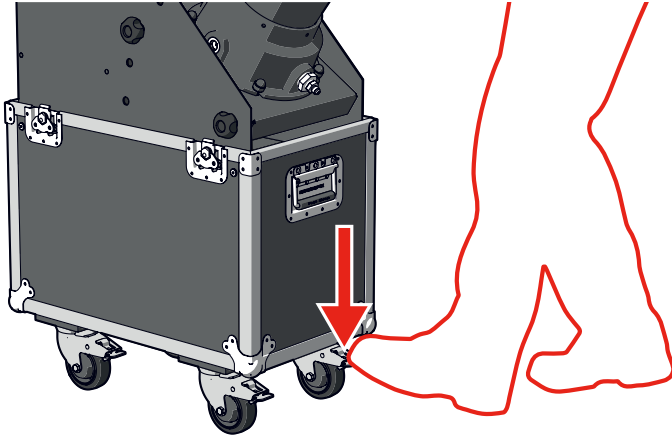

-
- 10 Take the necessary safety precautions, see Section 2.7.
-

- 11 Connect the CO₂ valve to the CO₂ input of the woofer and tighten the nut with the adjustable wrench.

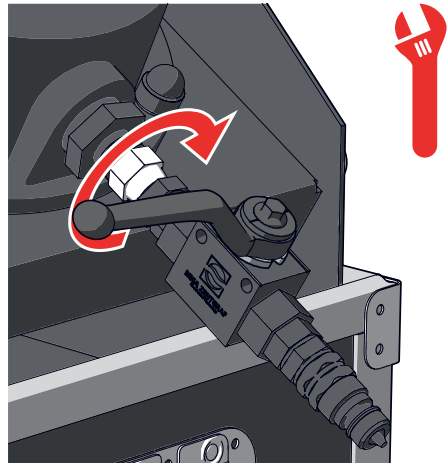
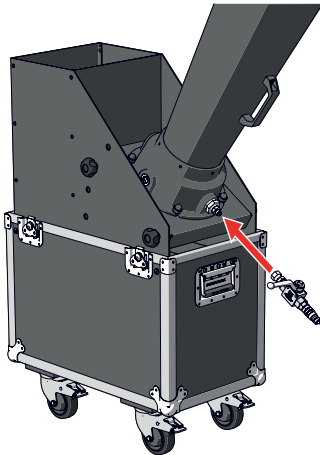

-
- 12** Connect the CO₂ hose to the CO₂ valve.

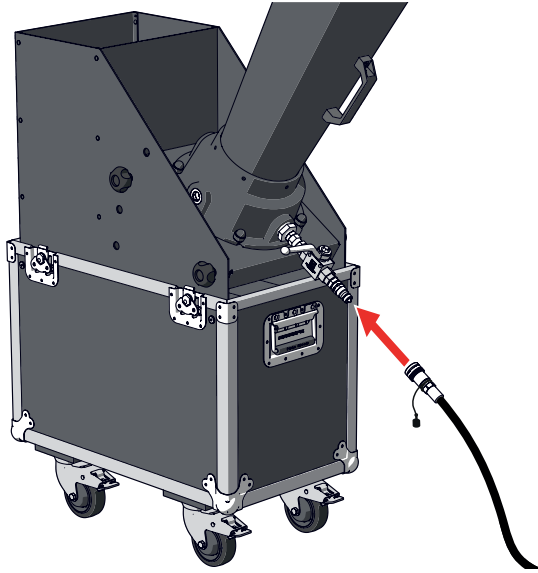

-
- 13** Make sure that the CO₂ valve is in CLOSED position.

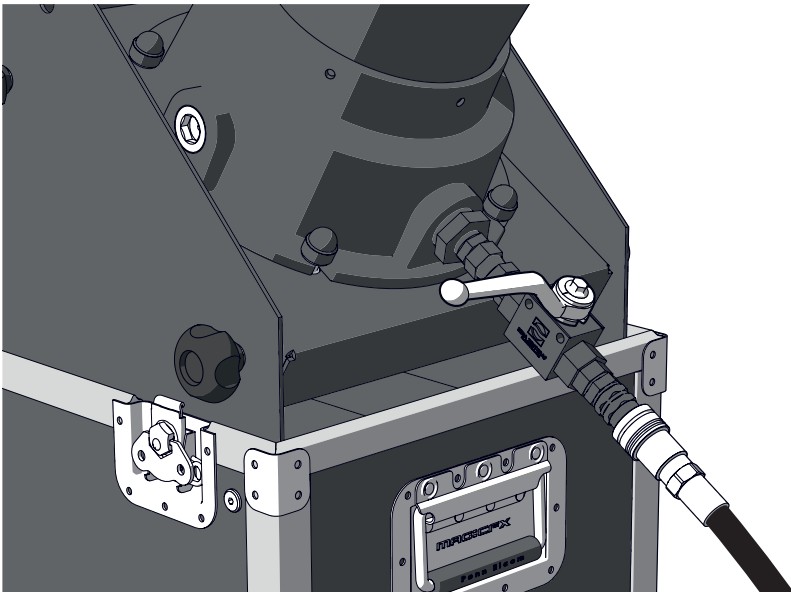

-
- 14** Connect the CO₂ Bottle to Hose Connector to a CO₂ cylinder.

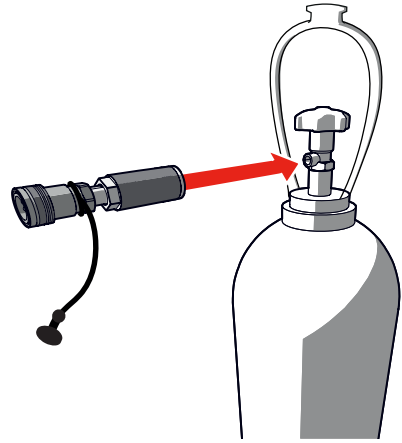

-
- 15** Connect the CO₂ hose to the CO₂ Bottle to Hose Connector on the CO₂ cylinder.

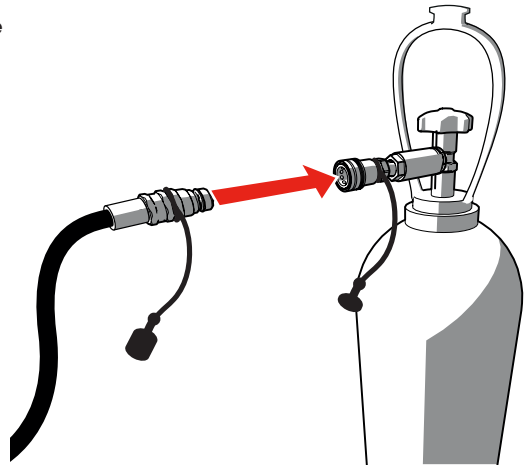

-
- 16** Open the CO₂ cylinder.

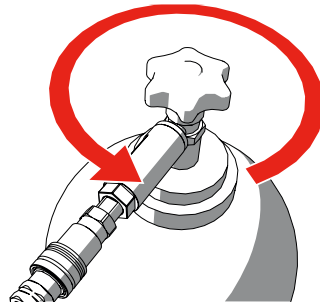

3.2 FILL WITH CONFETTI AND BLAST

1 Make sure that the prescribed safety zone is free from persons and objects.

2 When it's time to blast, move the manual CO₂ valve in OPEN position.

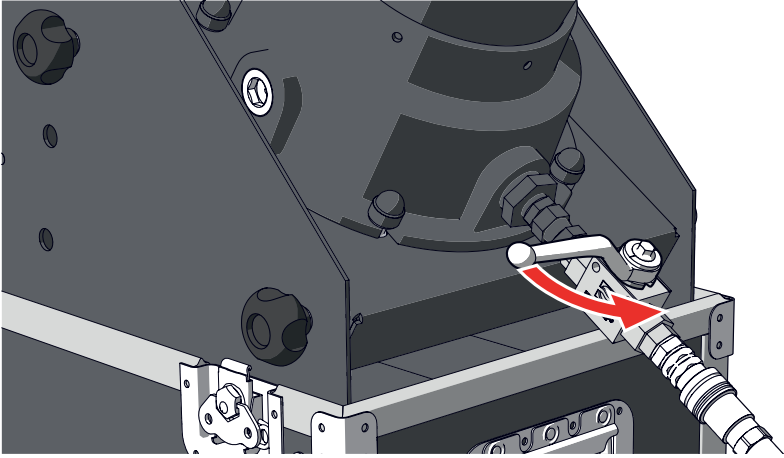

3 Keep filling the hopper with confetti by hand.

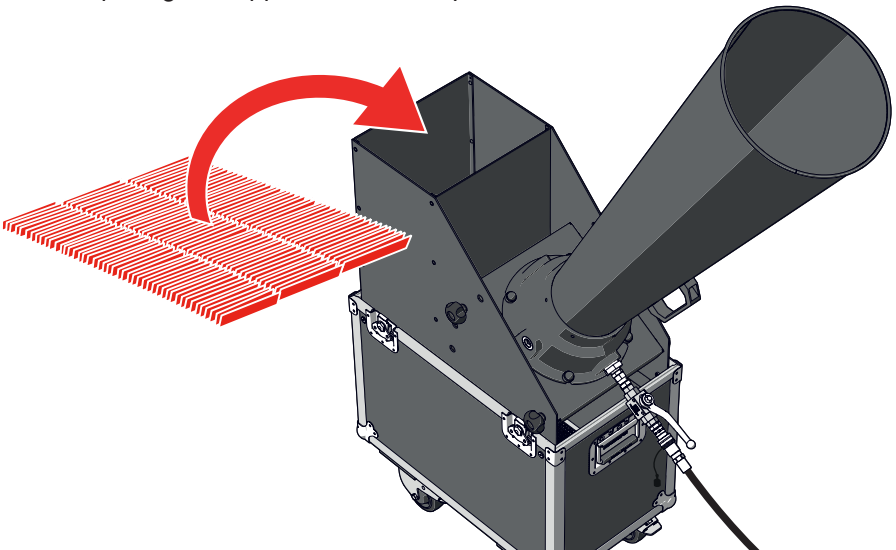

4 Enjoy the view!

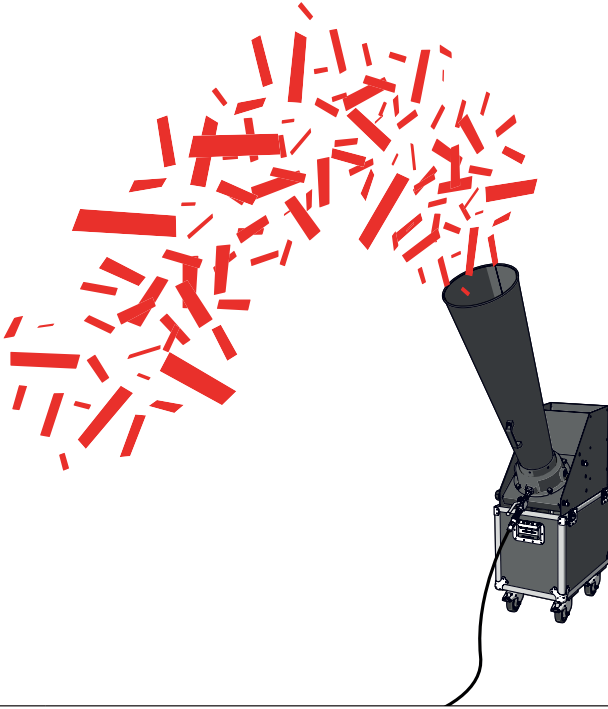

5 When you are finished with blasting confetti, move the manual CO₂ valve back in CLOSED position.

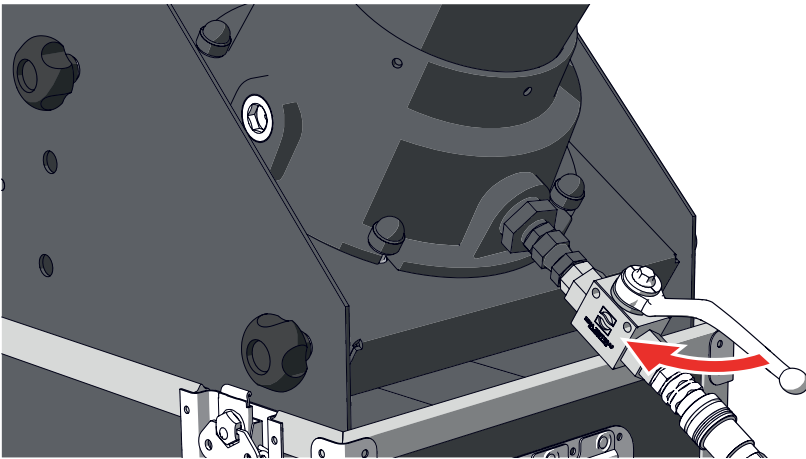

3.3 REPLACE A CO₂ CYLINDER

- 1 Make sure that the CO₂ valve is in CLOSED position.

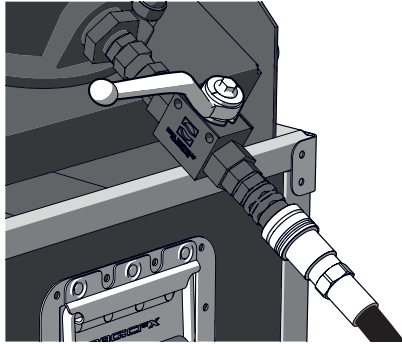

- 2 Close the connected CO₂ cylinder.

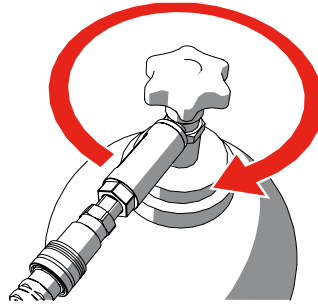

- 3 Move the manual CO₂ valve in OPEN position to release the pressure from the system.

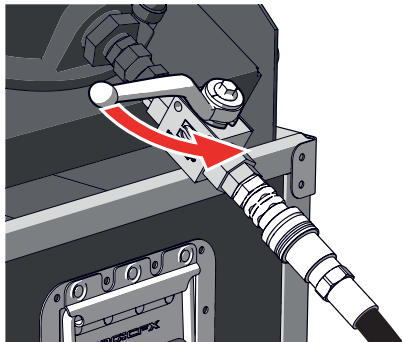

-
- 4** Disconnect the CO₂ hose from the CO₂ Bottle to Hose Connector on the CO₂ cylinder.

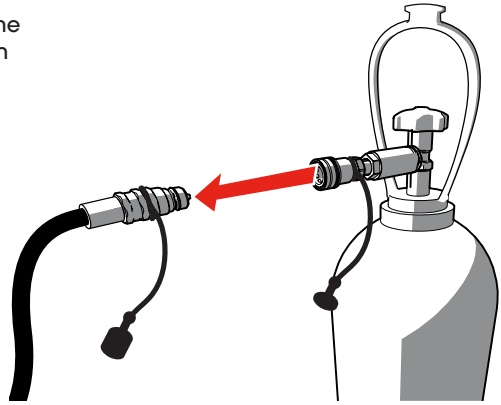

-
- 5** Remove the CO₂ Bottle to Hose Connector from the cylinder.

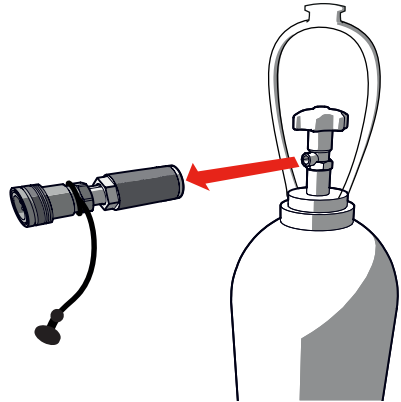

-
- 6** Connect a CO₂ Bottle to Hose Connector to a new CO₂ cylinder.

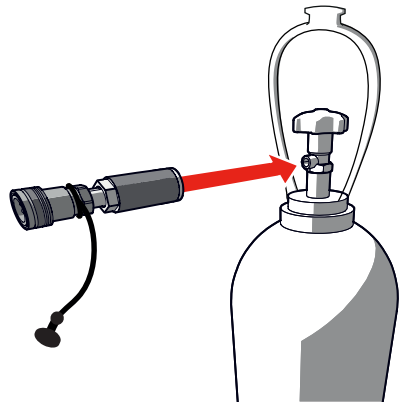

-
- 7 Connect the CO₂ hose to the CO₂ Bottle to Hose Connector on the new CO₂ cylinder.

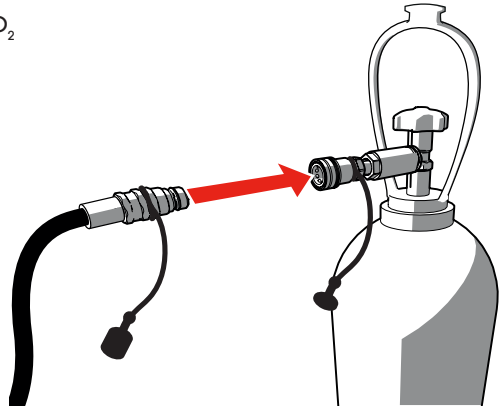

-
- 8 Move the manual CO₂ valve back in the CLOSED position.

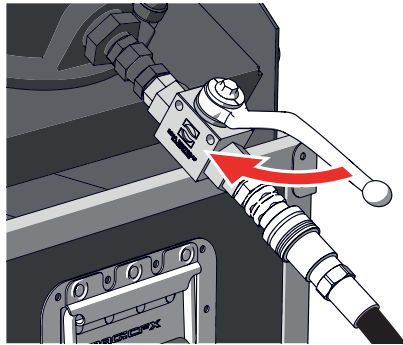

-
- 9 Open the CO₂ cylinder.

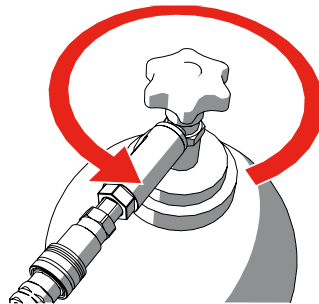

3.4 CLEAN UP

- 1 Close the connected CO₂ cylinder.

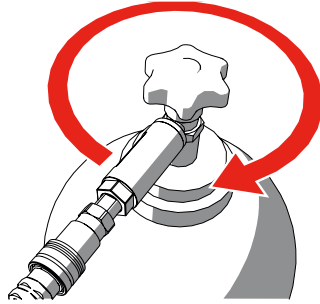

- 2 Move the manual CO₂ valve in OPEN position to release the pressure from the system.

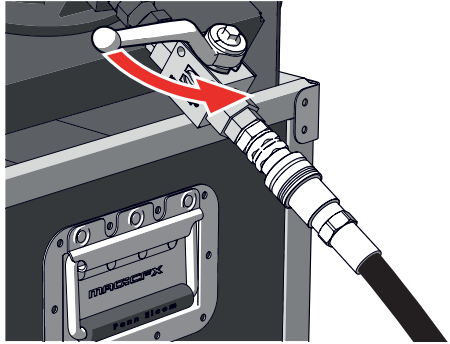

- 3 Remove the CO₂ hose.

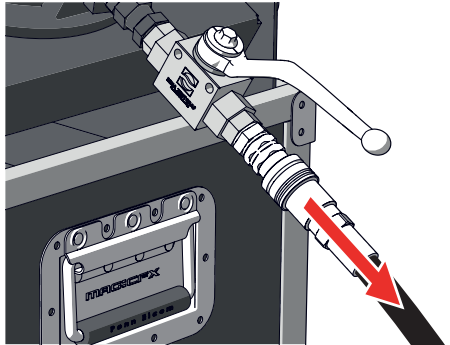

-
- 4 Disconnect the CO₂ hose from the CO₂ Bottle to Hose Connector on the CO₂ cylinder.

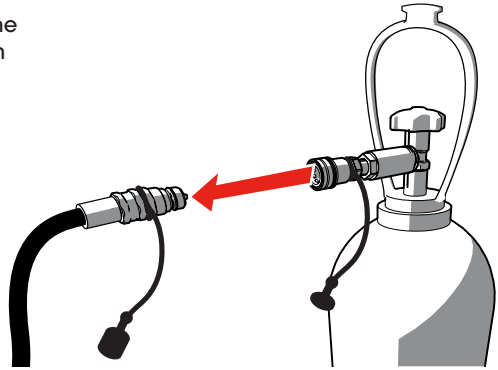

-
- 5 Remove the CO₂ Bottle to Hose Connector from the cylinder.

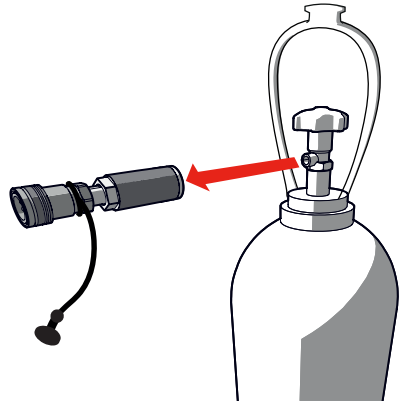

NOTICE

Fasteners in the vicinity of the output pipe can become frozen due to the use of CO₂. If necessary, wait until these fasteners are defrosted before you try to release them.

-
- 6 Unscrew the nut and remove the CO₂ valve.

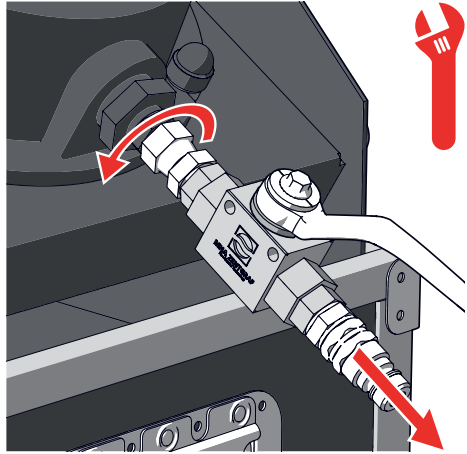

-
- 7 Unlock and remove the pins while holding the woofer and remove the woofer.

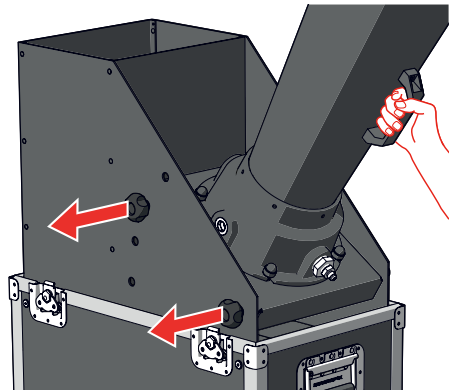

-
- 8 Remove remaining confetti from the hopper.

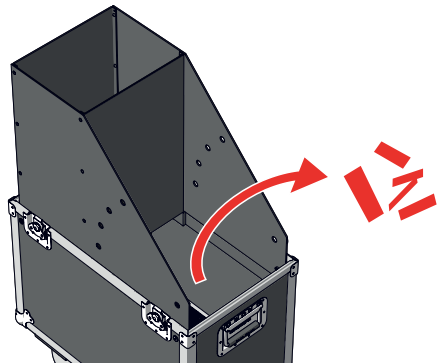

9 Store all parts in the case.

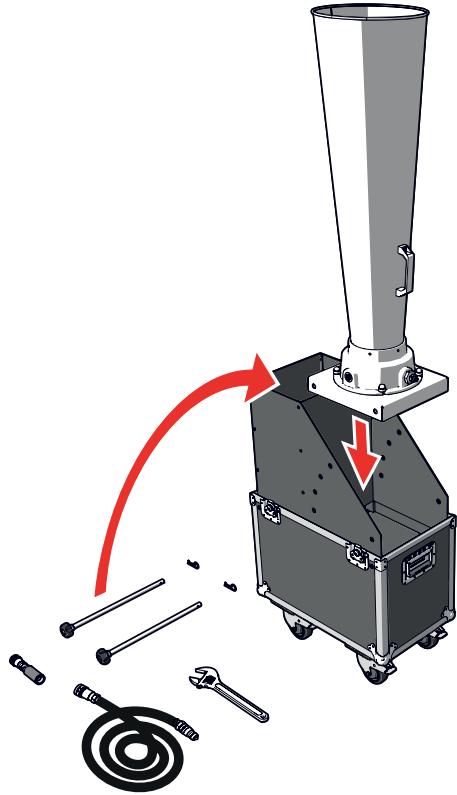

10 Place and lock the top cover.

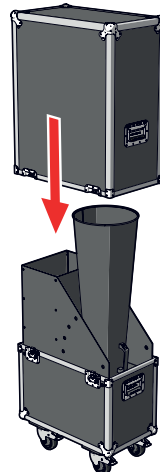

4 TROUBLESHOOTING

Always contact MAGIC FX if any malfunctions or errors occur that cannot be solved with the instructions as described in this manual.

5 MAINTENANCE

To achieve the maximum service life of the MAGICFX® SUPERBLASTER (XL) you must regularly clean the MAGICFX® SUPERBLASTER (XL) and test if it is functioning correctly.

Contact MAGIC FX if the MAGICFX® SUPERBLASTER (XL) is not functioning correctly.

⚠ DANGER

Do not replace parts yourself; always consult MAGIC FX if necessary.

6 CORRECT DISPOSAL



This symbol on the product and/or accompanying documents means that used electrical and electronic products should not be mixed with general household waste. For proper treatment, recovery and recycling, please take this product to designated collection points where it will be accepted free of charge.

Alternatively, in some countries you may be able to return your products to your local retailer upon purchase of an equivalent new product.

Disposing of this product correctly will help save valuable resources and prevent any potential negative effects on human health and the environment, which could otherwise arise from inappropriate waste handling.

Please contact your local authority for further details of your nearest designated collection point.

Penalties may be applicable for incorrect disposal of this waste, in accordance with your national legislation.

7 EC DECLARATION OF CONFORMITY

7.1 SUPERBLASTER

MAGIC FX B.V. declares as manufacturer and composer of the technical construction file that the product with the following specifications:

Name machine : SUPER BLASTER
Type : MFX0801
Serial number : on product
Year of construction : on product

Is in conformity with the minimal safety regulations as stated in the following directive(s):

- PED 2014/68/EU category 4.3, SEP
(products in this category cannot be provided with a CE-marking)

The following harmonized standards were applied:

- NEN-EN-ISO 12100:2010 Safety of machinery - General principles for design - Risk assessment and risk reduction.

Original declaration of conformity

Translation of the original declaration of conformity

Name manufacturer : MAGIC FX BV
Address : Schouwrooij 27, 5281 RE BOXTEL
Country : The Netherlands

CEO : B. Veroude
Date : 19-3-2019

Signature :



7.2 SUPERBLASTER XL

MAGIC FX B.V. declares as manufacturer and composer of the technical construction file that the product with the following specifications:

Name machine : SUPER BLASTER XL
Type : MFX0802
Serial number : on product
Year of construction : on product

Is in conformity with the minimal safety regulations as stated in the following directive(s):

- PED 2014/68/EU category 4.3, SEP
(products in this category cannot be provided with a CE-marking)

The following harmonized standards were applied:

- NEN-EN-ISO 12100:2010 Safety of machinery - General principles for design - Risk assessment and risk reduction.

- Original declaration of conformity
 Translation of the original declaration of conformity

Name manufacturer : MAGIC FX BV
Address : Schouwrooij 27, 5281 RE BOXTEL
Country : The Netherlands

CEO : B. Veroude
Date : 19-3-2019

Signature :



MAG:CFX[®]

WWW.MAGICFX.EU

